

Gap Mill GM-P

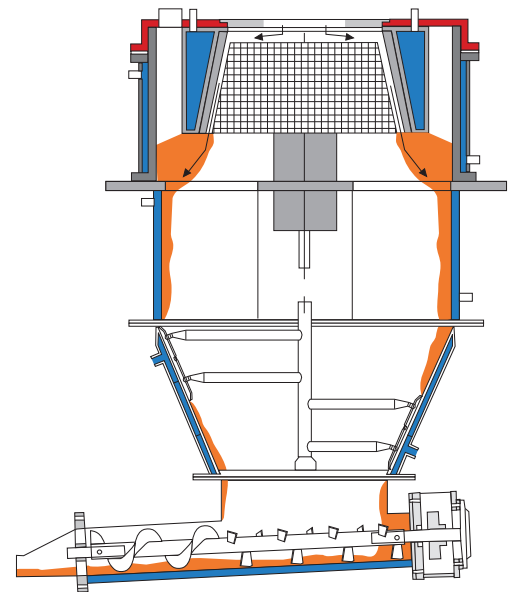

Key Features

- For wet grinding applications.
- Available in 3 sizes, the nominal diameter of the rotors being 400 mm, 800 mm and 1,200 mm.
- Rotor rotation is reversible to extend use and minimize down time.
- Adjustable grinding gap for fine to coarse grinds.
- Variable frequency drive available.
- Constructed of carbon steel or stainless steel.
- Drive power from 40 Hp up to 250 Hp available with rotor tip speeds up to 123 meters/second.



Overview

The Bauermeister Gap Mill is a unique design for fine and ultra-fine grinding of nut and confectionery based products, including slurry based feed for fine grinding and homogenization. Fully water jacketed construction with internal scraper assembly to aid in free flow of product and increase in water jacket efficiency. This feature is especially helpful on high viscous products.

The conical shape of the rotor allows the mill to impact the product with increased tip speeds as the particles pass through the grinding area. For example, at 123 m/s medium tip speed, particles enter the grinding area with a tip speed of 115 m/s and this increases until the tip speed exceeds 130 m/s at the exit of the grinding area. When used on nut products, the GM-P is capable of reducing a nut feed to a very fine paste in one step. Thus eliminating the traditional multistep process.



Rotor



Stator

