

**Automatic Open-Mouth Bagger  
7115XC**



**Features:**

- Simple in-line design delivers total bag control for faster filling and better bag seals
- Single adjustable carriage handles paper or poly bag widths from 11" to 20"
- Filling spout moves down into bag for fast filling with minimal dusting
- Simple vacuum transducers replace vacuum pumps, motors, switches, valves, starters, and filter
- Fewer parts and less downtime
- Bag infeed system delivers accurate bag placement even with wrinkled bags and inconsistent stacks

**Barry-Wehmler**

# Automatic Open-Mouth Bagger 7115XC

The 7115XC Automatic Open-Mouth Bagger is a simple, reliable, highly accurate system for bagging free-flowing products in 20 to 100 lb. paper, poly, or woven polypropylene bags at speeds of up to 20 bags per minute.

The simple in-line design provides total bag control throughout the placement,

opening, filling, and reforming operation. Spillage is virtually eliminated, maintenance is simple, and changeovers take only minutes without tools. Even dusty products are not a problem. The system's specialized "duck bill" filling spout moves down into the bag prior to filling, which reduces blow-back and dusting.

## Additional Features:

- Single carriage handles all bag face widths from 11" to 20"
- Changeovers take from 3 to 5 minutes without tools
- Product hopper spout lowers into bag for fast filling with minimal dusting
- Single shaker/saddle design cuts adjustment time, and improves product settling
- User-friendly operator interface lets operator fine tune bagger operation easily

## Machine Specifications

- **PRODUCTION SPEED:** Up to 20 bags per minute
- **BAG SIZES:**
  - Paper Bags*
  - Face Width: 11" to 20" (279 mm to 508 mm)
  - Bag Length:
    - PBOM: 21" to 42" (533 mm to 1067 mm)
    - SOM: 20" to 41" (508 mm to 1016 mm)
  - Plastic Bags*
  - Face Width: 11" to 20" (279 mm to 508 mm)
  - Bag Length: 20" to 40" (508 mm to 1016 mm)
- **ELECTRICAL REQUIREMENTS:**
  - Input Power: 230/460 volt, 3 phase, 60 hz
  - Control Circuit: 115 volt
  - Max. Current Draw: 230 volt ... 22 amps  
460 volt ... 11 amps
- **AIR REQUIREMENTS:**
  - Operating Pressure: 80 psi (5.4 atm)
  - Line Pressure: 90 psi (6.1 atm)
  - Free Air Per Cycle: 1.4 cubic feet (39.2 liters)
- **WEIGHT (APPROXIMATE):**
  - Approximately 4,500 lbs. (2,475 kg)

Specifications are subject to change without notice. All sales are subject to our prevailing terms and conditions. Product, bags, and application requirements must be submitted for appraisal. Specific application approval drawings will be provided.

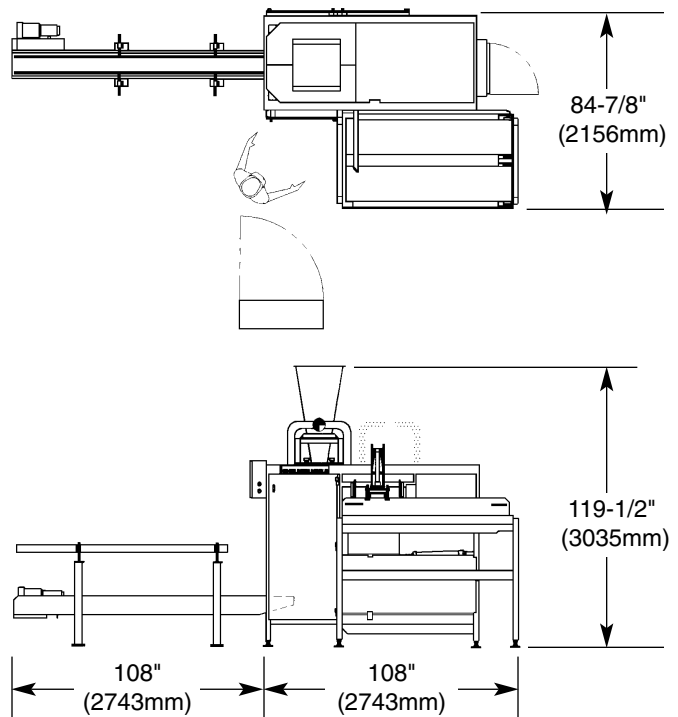

## Thiele Technologies, Inc.

A BARRY-WEHMILLER COMPANY

www.thieletech.com

sales@thieletech.com

BP 00000 07/00 2.5M

315 27th Avenue Northeast  
Minneapolis, MN 55418-2715 USA  
612/782-1200 fax 612/782-1209